



Automation for a Changing World

Delta Elevator Drive ED Series



www.deltaww.com



DELTA
Smarter. Greener. Together.



Elevator Drive - ED Series

Delta introduces its new elevator control solution: the Elevator Drive ED Series. Developed with years of elevator control experience from Delta's elevator drive VFD-VL series, the ED series is an extended version designed with more advanced features and higher performance.

The Delta ED series is UL/CE certified ensuring the best operation reliability. Designed to high safety standards and for high durability, the ED series is an excellent solution for elevator operation in critical environments. It provides versatile and flexible control functions, and an especially smooth start and stop. Smooth operation is critical for providing passengers a safe and comfortable ride. Delta's ED series delivers the optimal operation efficiency for both passenger and cargo elevators.

Delta has a global service network always available to provide instant technical support and professional service. The Elevator Drive ED series is your most reliable choice for high performance elevator control.



Features

- Supports both asynchronous and synchronous motors
- Auto-tuning with the load attached
- Auto-adjust starting torque, load compensation, manual control
- Precise time sequence for elevator motion (start/stop)
- Compact size for easy installation in the elevator control cabinet with more space available
- Dual-output protection for reliable rides
- Supports 1-phase 230V_{AC} Uninterrupted Power System (UPS)
- Built-in LED keypad and an optional removable LCD keypad available upon purchase

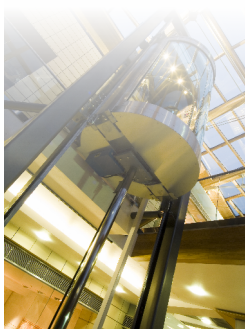

Features

Simple Instructions

- ▶ **Auto-tuning with the load attached**
 - Ability to perform auto-tuning with load when elevator structure is complete
 - Supports all types of encoders
 - Precisely measures the motor parameters and PG offset angle
 - Load balance without adding additional loads, safe and convenient
- ▶ **Auto-homing mode reduces maintenance costs**
- ▶ **Built-in LED digital keypad. Removable digital keypad is available upon purchase**
- ▶ **Compact control box design strengthens the drive structure**



■ Slim body design 146mm

Comfort Ride

- ▶ **Efficient scheduling of operation provides precise control to achieve smooth start and stop**

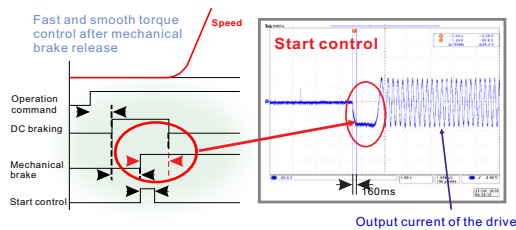

- ▶ **DC braking leveling and slip compensation functions enhance the leveling accuracy and provide a comfortable ride**

Safety Ensured

- ▶ **Dual output protection for a reliable ride**
 - Auto-detect output phase loss to ensure proper motor operation
 - Auto-check torque output before the mechanical brake is released



Dual output protection mechanisms strictly ensure elevator operation for passenger safety

- ▶ **Emergency operation**
 - Supports single-phase 230V_{AC} Uninterrupted Power System (UPS). Light-load direction search function is triggered automatically when power failure occurs
- ▶ **Built-in STO (Safe Torque Off) function**
 - Compliant with EN61800-5-2 (STO) and EN61508 (SIL2) standards for high safety protection and reliability
 - Less output contactors are required compared to traditional installation methods. Saves on installation cost

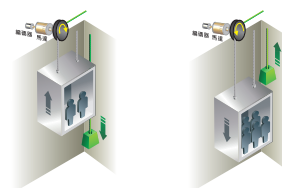

Light load direction search function is activated when power failure occurs. It brings the elevator to the nearest floor safely.

System Structure

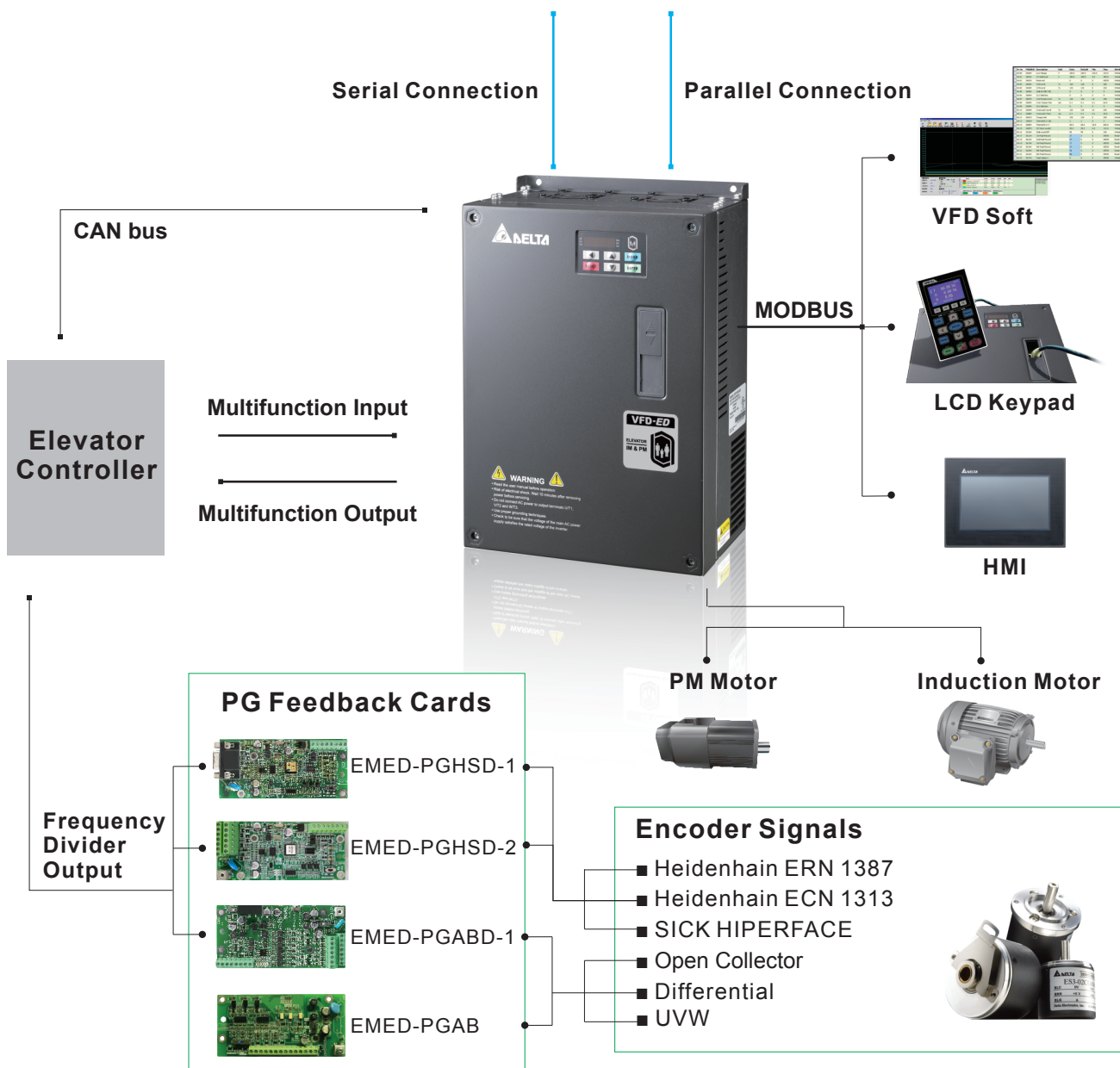
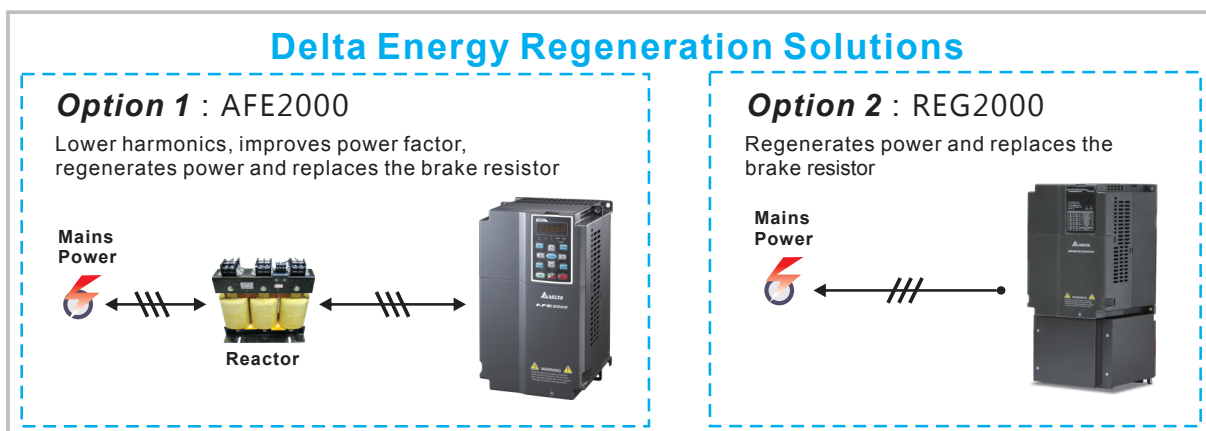

Control Terminals

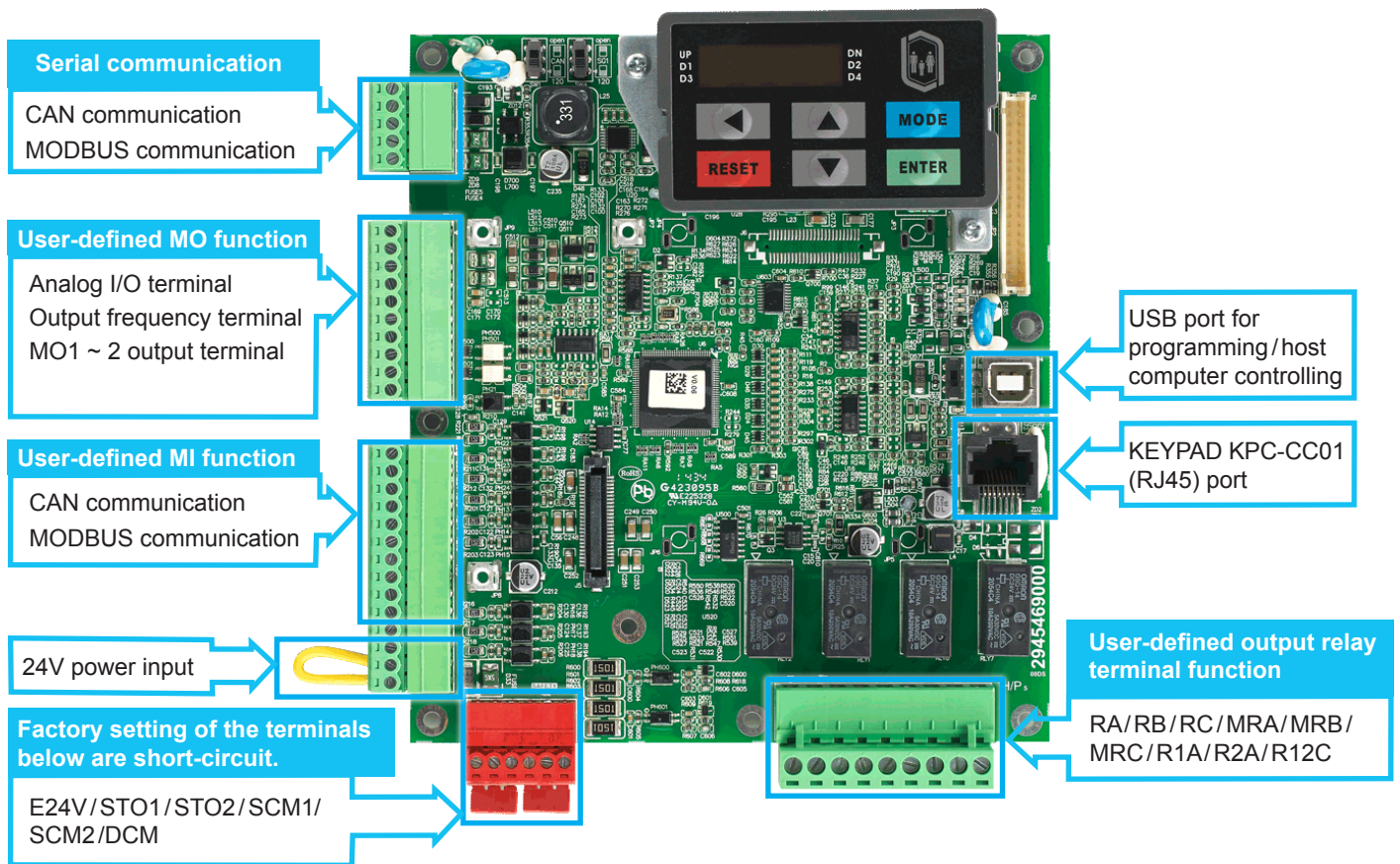

Name	Quantity	Terminal
Multifunction digital input (MI)	FWD x 1 REV x 1 MI x 8	1. FWD: Forward Run/Stop 2. REV: Reverse Run/Stop 3. MI1 ~ MI8 user-defined functions 4. Input impedances: app. 3.75kΩ 5. Input voltage range: 0 ~ 24V _{DC}
Analog input terminal (AUI)	2 units	1. User-defined functions 2. Input range: -10 ~ +10V 3. Input impedance = 20kΩ
Multifunction relay output terminal	4 units (Normally Open/ Normally Close)	1. User-defined functions 2. 3A(N.O.)/3A(N.C.) 250V _{AC} 5A(N.O.)/3A(N.C.) 30V _{DC} (min. 5V _{DC} , 10mA)
Output frequency terminal (MO)	2 units	1. User-defined functions 2. Max. 48V _{DC} 50mA
Analog output terminal (AFM)	2 units	1. User-defined functions 2. Max. load: 5kΩ 3. Output current: Max. 2mA 4. Resolution : 0 ~ 10V corresponds to the max. operation frequency 5. Range: 0 ~ 10V → -10 ~ +10V
Safety Torque Off (STO) terminal	2 units	1. Power removal safety function for EN954-1 and IEC/EN61508 2. Factory setting of E24V/STO1/STO2 is short-circuit. 3. Factory setting of SCM1/SCM2/DCM is short-circuit. 4. When STO1 ~ SCM1; STO2 ~ SCM2 is activated, the activation current is 3.3mA ≥ 11V _{DC}
Serial communication ports	2 units	1. CAN communication 2. MODBUS communication
USB port	1 unit	1. Programming/host computer controlling

Wiring

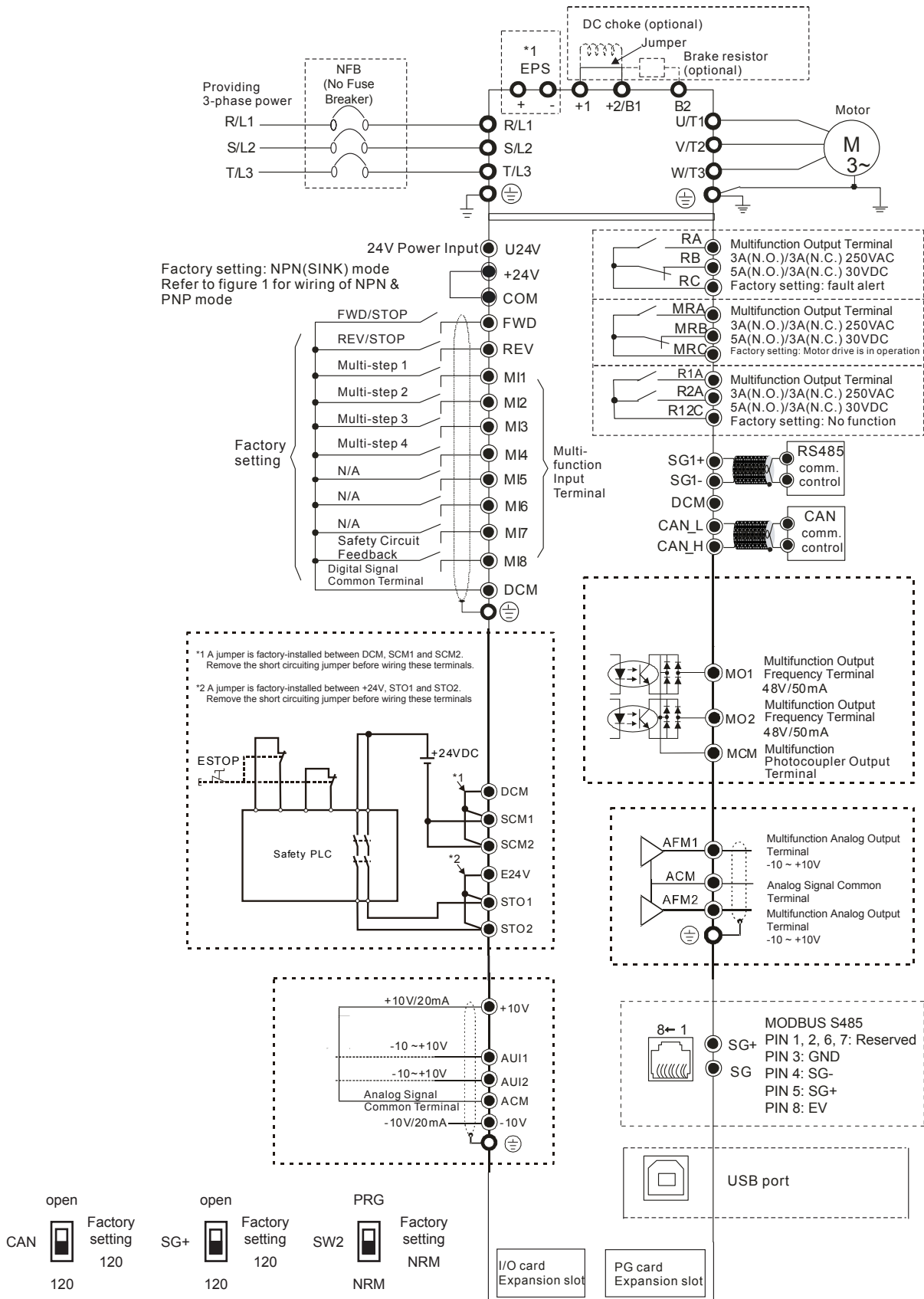

Specifications

Model Name



Frame Size		230V											
		B			C			D			E		
Model VFD-__ED23/21S		022*	037*	40	55	75	110	150	185	220	300	370	
Applicable Motor Output (KW)		2.2	3.7	4	5.5	7.5	11	15	18.5	22	30	37	
Applicable Motor Output (HP)			5	5	7.5	10	15	20	25	30	40	50	
Output Rating	Rated Output Capacity (KVA)	4.8	6.8	7.9	9.5	12.5	19	25	29	34	46	55	
	Rated Output Current (A)	12.0	17	20.0	24.0	30.0	45.0	58.0	77.0	87.0	132.0	161.0	
	Maximum Output Voltage (V)	3-phase proportional to input voltage											
	Output Frequency	0.00 ~ 400Hz											
	Carrier Frequency	2 ~ 15kHz									2 ~ 9kHz		
	Rated Output Maximum Carrier Frequency	8kHz			10kHz			8kHz			6kHz		
Input Rating	Input Current (A)	24	34	20	23	30	47	56	73	90	132	161	
	Rated Voltage / Frequency	Single-phase 200 ~ 240V 50/60Hz				3-phase 200 ~ 240V 50/60Hz							
	Voltage Tolerance	±10% (180 ~ 264V)											
	Frequency Tolerance	±5% (47 ~ 63Hz)											
Cooling Method		Fan cooling											
Weight (kg)		6	6	6	8	10	10	13	13	13	36	36	

*VFD022ED21S & VFD037ED21S are single phase model

Frame Size		460V											
		B	C			D			E				
Model VFD-__ED43S		40	55	75	110	150	185	220	300	370	450	550	750
Applicable Motor Power (KW)		4	5.5	7.5	11	15	18.5	22	30	37	45	55	75
Applicable Motor Power (HP)		5	7.5	10	15	20	25	30	40	50	60	75	100
Output Rating	Rated Output Capacity (KVA)	9.2	10.4	13.5	18.3	24	30.3	36	46.2	63.7	80	96.4	116.3
	Rated Output Current (A)	11.5	13	17	23	30	38	45	58	80	100	128	165
	Maximum Output Voltage (V)	3-phase 380 ~ 480V, 50/60Hz											
	Output Frequency	0.00 ~ 400Hz											
	Carrier Frequency	2 ~ 15kHz						2 ~ 9kHz			2 ~ 6kHz		
	Rated Output Maximum Carrier Frequency	8kHz	10kHz			8kHz			6kHz				
Input Rating	Rated Input Current (A)	11.5	14	17	24	30	37	47	58	80	100	128	165
	Rated Voltage	3-phase 380 ~ 480V, 50/60Hz											
	Voltage Tolerance	±10% (342 ~ 528V)											
	Frequency Tolerance	±5% (47 ~ 63Hz)											
Cooling Method		Fan cooling											
Weight (kg)		6	8	10	10	10	10	13	14.5	36	36	50	50

The measure of input and output current is influenced by the power supply, input reactor, wiring cables and the power supply impedance applied to the AC motor drive.



General Specifications

Protection Characteristics	Control Method	1: V/F, 2: VF+PG, 3: SVC, 4: FOC+PG, 5: TQC+PG, 6: FOC+PM
	Starting Torque	Reach up to 150% or above at 0.5Hz. Under FOC+PG or FOC+PM mode, starting torque can reach 150% at 0Hz.
	Speed Control Range	1:100 (up to 1:1000 when using PG card)
	Speed Control Resolution	±0.5% (up to ±0.02% when using PG card)
	Speed Response Ability	5Hz (Up to 30Hz for vector control)
	Max. Output Frequency	0.00 to 400Hz
	Output Frequency Accuracy	Digital Command 0.005%, Analog Command 0.5%
	Frequency Setting Resolution	Digital Command 0.01Hz, Analog Command: 1/4096 (12 bit) of the max. output frequency.
	Torque Limit	Max. is 190% torque current
	Torque Accuracy	±5%
	Accel/Decel Time	0.00 ~ 600.00 seconds
	V/F Curve	Adjustable V/F curve using 4 independent points and square curve.
	Frequency Setting Signal	±10V
Protection Characteristics	Motor Protection	Electronic thermal relay protection.
	Over-current Protection	Over-current protection for 250% rated current Current clamp for 190% rated current
	Ground Leakage Current Protection	Higher than 50% rated current
	Overload Ability	Constant torque: 150% for 60 seconds, variable torque: 190% for 5 seconds
	Over-voltage Protection	Over-voltage level: $V_{DC} > 400/800V$; low-voltage level: $V_{DC} < 200/400V$
	Over-voltage Protection for the Input Power	Varistor (MOV)
	Over-temperature Protection	Built-in temperature sensor
Environment	Protection Level	NEMA 1/IP20
	Operation Temperature	-10°C~ 40°C, Up to 50°C under derating operation
	Storage Temperature	-20°C~ 60°C
	Ambient Humidity	Below 90% RH (non- condensing)
	Vibration	1.0G less than 20Hz, 0.6G at 20 ~ 60Hz
	Installation Location	Altitude 1,000m or lower, keep from corrosive gasses, liquid and dust.
	Power System	TN System ^{*1 *2}
Certifications	  (UL mark excludes VFD022ED21S and VFD037ED21S)	

*1 TN System: The neutral point of the power system is connected to the ground directly. The metal components that are exposed to air are connected to the ground via the protective earth conductor.
*2 Single-phase models have a three wire single-phase system design.

Dimensions

■ Frame B

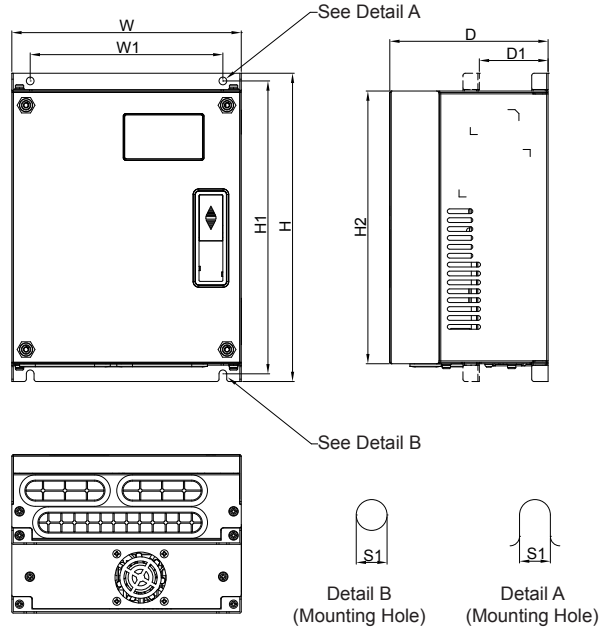

MODEL

VFD022ED21S VFD040ED43S
 VFD037ED21S
 VFD040ED23S

Frame		W	W1	H	H1	H2	D	D1*	S1
B	mm	193.5	162.5	260.0	247.0	230.0	133.5	58.0	6.5
	inch	7.60	6.39	10.22	9.71	9.04	5.25	2.28	0.26

*D1: This dimension is for flange mounting application reference.

■ Frame C

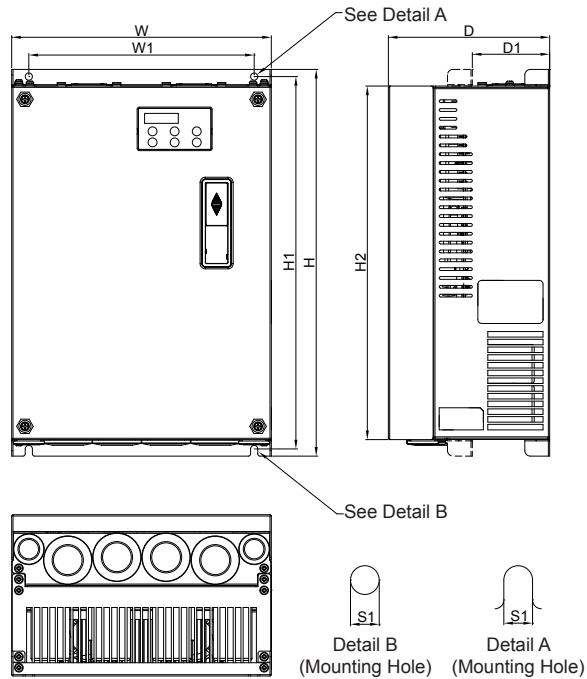

MODEL

VFD055ED23S VFD055ED43S
 VFD075ED23S VFD075ED43S
 VFD110ED23S VFD110ED43S
 VFD150ED43S
 VFD185ED43S

Frame		W	W1	H	H1	H2	D	D1*	S1
C	mm	235.0	204.0	350.0	337.0	320.0	146.0	70.0	6.5
	inch	9.25	8.03	13.78	13.27	15.60	5.75	2.76	0.26

*D1: This dimension is for flange mounting application reference.

■ Frame D

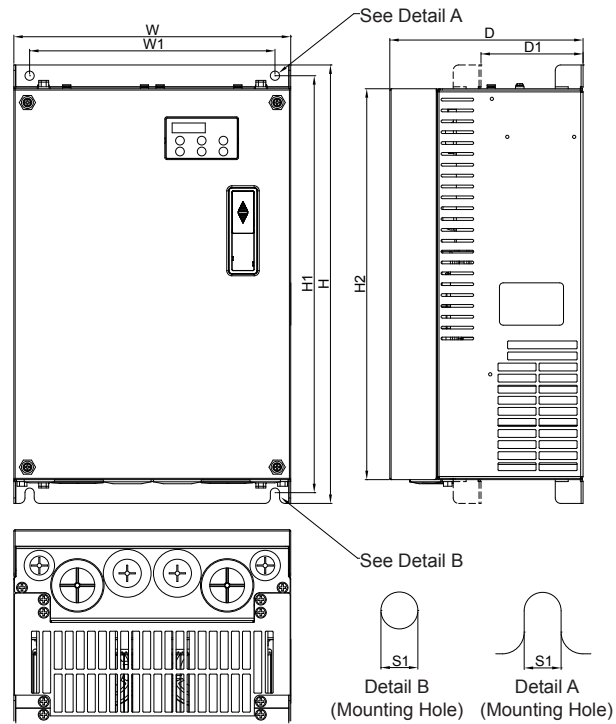

MODEL

VFD150ED23S VFD220ED43S
 VFD185ED23S VFD300ED43S
 VFD220ED23S

Frame		W	W1	H	H1	H2	D	D1*	S1
D	mm	255.0	226.0	403.8	384.0	360.0	178.0	94.0	8.5
	inch	10.4	8.9	15.9	15.12	14.17	7.01	3.70	0.33

*D1: This dimension is for flange mounting application reference.

■ Frame E

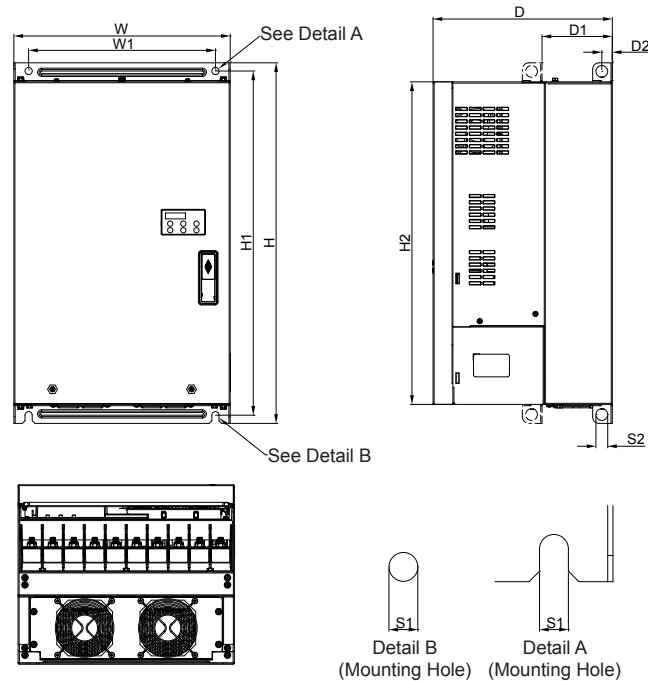

MODEL

VFD220ED43S VFD370ED43S
 VFD300ED43S VFD450ED43S
 VFD550ED43S
 VFD750ED43S

Frame		W	W1	H	H1	H2	D	D1*	D2	S1	S2
E	mm	330.0	285.0	550.0	525.0	492.0	273.4	107.2	16.0	11.0	18.0
	inch	12.99	11.22	21.65	20.67	19.37	10.76	4.22	0.63	0.43	0.71

*D1: This dimension is for flange mounting application reference.

Accessories

PG Card

Supports open collector, line driver and UVW encoder signals

Terminals	Descriptions
VP	Output power of encoder Output voltage: +5V/+12V (determined by SW1) Maximum output current: 200mA
0V	Power source common for encoder
A, /A, B, /B, Z, /Z	Incremental encoder signal input Line driver input complies to the RS422 standard Single-phase input of +12V open collector signal (can be set by SW2) Maximum input frequency: 100kHz
U, /U, V, /V, W, /W	Hall sensor signal input Maximum input frequency: 50kHz
SW1, SW2	Encoder voltage: +5V/12V Input encoder signal: open collector or line driver

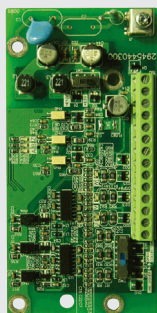

EMED-PGAB

PG Card

Supports Heidenhain ERN1387/ECN1313, SICK HIPERFACE

Terminals	Descriptions	
Vin	Port for voltage input (for adjusting the value of voltage amplitude from push-pull pulse output) Maximum input voltage: 24 V _{DC}	
GND	Power source common for encoder	
A/O, B/O	Push-pull pulse output signal Maximum output frequency: 50kHz	
AO, /AO, BO, /BO	Line driver pulse output signal Maximum output frequency: 100kHz	
PGHSD-1	PGHSD-2	Encoder signal input Support Heidenhain ERN1387 encoder Heidenhain EnDat 2.1 SICK HIPERFACE
D-SUB Connector (J3)	Terminal Block Connector (TB2)	
SW1	Switch between output IN.P/EX.P	
SW2	Switch between encoder power 5V/8V	



EMED-PGHSD-1



EMED-PGHSD-2

PG Card

Supports open collector, differential, UVW signal and frequency divider output

Terminals	Descriptions
Vin	Port for voltage input, to adjust the amplitude of output voltage at terminal A/O and terminal B/O.
GND	Common ground terminal connecting to the host controller and the motor drive.
A/O, B/O	Output signal of the push-pull frequency divider Factory setting: Output amplitude is about +24V. Use SW2 to cut off the internal default power. Input required power (i.e. output voltage's amplitude) Max. output frequency: 100kHz Frequency dividing range: 1 ~ 31Hz
AO, /AO, BO, /BO	Line driver pulse output signal Maximum output frequency: 150kHz Frequency dividing range: 1 ~ 31Hz
VP	Power output of encoder Note: Use SW1 to set up output voltage Voltage: +5V±0.5V or +12V±1V Current: Max. 200mA
0V	Common power terminal of encoder
A, \bar{A} , B, \bar{B} , Z, \bar{Z}	Incremental encoder signal input (differential motion, voltage, push-pull, open collector) Note: Different input signal needs different wiring method. See user manual for wiring diagrams. Maximum input frequency: 150kHz
U, \bar{U} , V, \bar{V} , W, \bar{W}	Absolute encoder signal input (differential motion, voltage, push-pull, open collector) Note: Different input signal needs different wiring method. See user manual for wiring diagrams. Maximum input frequency: 150kHz
SW1	Switch between encoder power 5V/12V
SW2	Switch between OPEN-C/LINE-D
SW3	Switch between output IN.P/EX.P

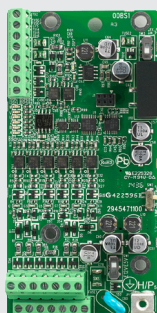

EMED-PGABD-1

Accessories



KPC-C01

- High illuminated LCD display
- MODBUS RS-485
- Languages:
 - English
 - Traditional Chinese
 - Simplified Chinese

Ordering Information

Frame	Applicable Models	Applicable Models	
		230V	460V
Frame B 	230V: 2.2kW ~ 4kW 460V: 4kW	VFD022ED21S VFD037ED21S VFD040ED23S	VFD040ED43S
Frame C 	230V: 5.5kW ~ 11kW 460V: 5.5kW ~ 18.5kW	VFD055ED23S VFD075ED23S VFD110ED23S	VFD055ED43S VFD075ED43S VFD110ED43S VFD150ED43S VFD185ED43S
Frame D 	230V: 15kW ~ 22kW 460V: 22kW ~ 30kW	VFD150ED23S VFD185ED23S VFD220ED23S	VFD220ED43S VFD300ED43S
Frame E 	230V: 30kW ~ 37kW 460V: 37kW ~ 75kW	VFD300ED23S VFD370ED23S	VFD370ED43S VFD450ED43S VFD550ED43S VFD750ED43S

Global Operations

ASIA (Taiwan)



Taoyuan Technology Center (Green Building)



Taoyuan Plant 1



Taoyuan Plant (Diamond-rated Green Building)

ASIA (China)



Wujiang Plant 3



Delta Electronics

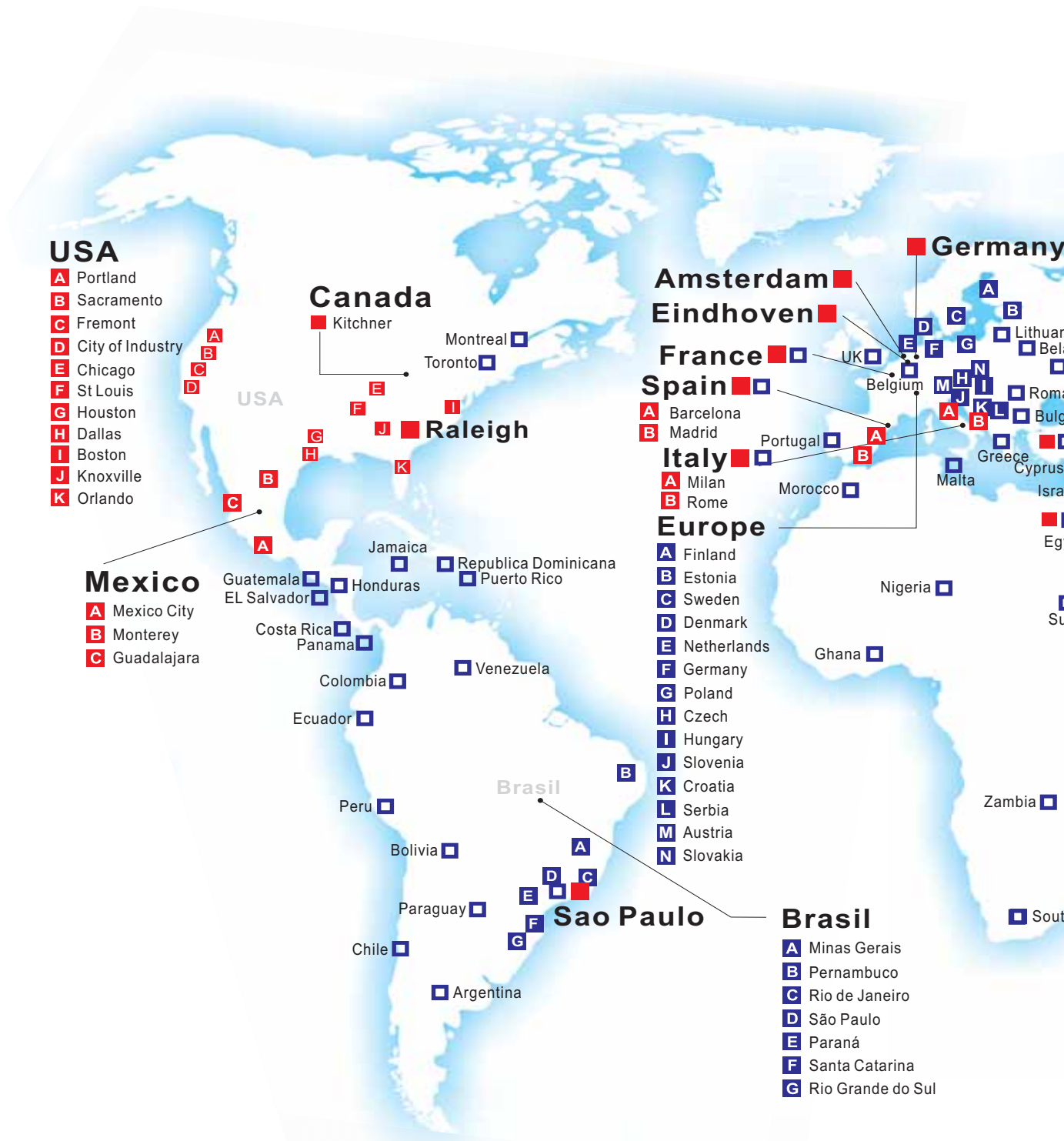

ASIA (Japan)



Tokyo Office

ASIA (India)



Rudrapur Plant
(Green Building)

EUROPE



Amsterdam, Netherlands

AMERICA



Research Triangle Park

▲ Factories 4 ■ Branch Offices 89 ● R&D Centers 5 ■ Distributors 635

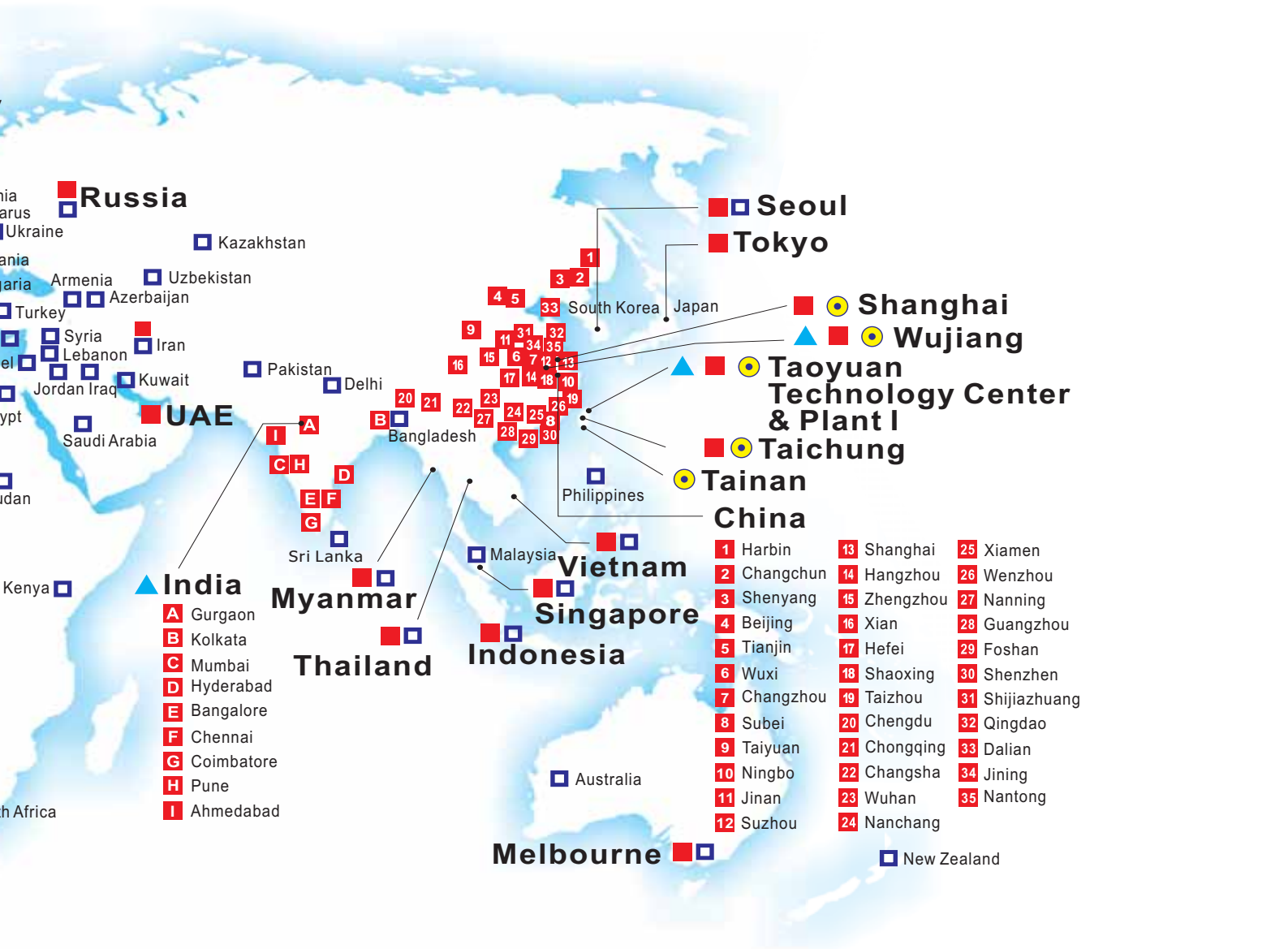



Smarter. Greener. Together.

Industrial Automation Headquarters

Delta Electronics, Inc.

Taoyuan Technology Center
No.18, Xinglong Rd., Taoyuan City,
Taoyuan County 33068, Taiwan
TEL: 886-3-362-6301 / FAX: 886-3-371-6301

Asia

Delta Electronics (Jiangsu) Ltd.

Wujiang Plant 3
1688 Jiangxing East Road,
Wujiang Economic Development Zone
Wujiang City, Jiang Su Province,
People's Republic of China (Post code: 215200)
TEL: 86-512-6340-3008 / FAX: 86-769-6340-7290

Delta Greentech (China) Co., Ltd.

238 Min-Xia Road, Pudong District,
ShangHai, P.R.C.
Post code : 201209
TEL: 86-21-58635678 / FAX: 86-21-58630003

Delta Electronics (Japan), Inc.

Tokyo Office
2-1-14 Minato-ku Shibadaimon,
Tokyo 105-0012, Japan
TEL: 81-3-5733-1111 / FAX: 81-3-5733-1211

Delta Electronics (Korea), Inc.

1511, Byucksan Digital Valley 6-cha, Gasan-dong,
Geumcheon-gu, Seoul, Korea, 153-704
TEL: 82-2-515-5303 / FAX: 82-2-515-5302

Delta Electronics Int'l (S) Pte Ltd

4 Kaki Bukit Ave 1, #05-05, Singapore 417939
TEL: 65-6747-5155 / FAX: 65-6744-9228

Delta Electronics (India) Pvt. Ltd.

Plot No 43 Sector 35, HSIIDC
Gurgaon, PIN 122001, Haryana, India
TEL : 91-124-4874900 / FAX : 91-124-4874945

Americas

Delta Products Corporation (USA)

Raleigh Office
P.O. Box 12173,5101 Davis Drive,
Research Triangle Park, NC 27709, U.S.A.
TEL: 1-919-767-3800 / FAX: 1-919-767-8080

Delta Greentech (Brasil) S.A

Sao Paulo Office
Rua Itapeva, 26 - 3° andar Edificio Itapeva One-Bela Vista
01332-000-São Paulo-SP-Brazil
TEL: +55 11 3568-3855 / FAX: +55 11 3568-3865

Europe

Delta Electronics (Netherlands) B.V.

Eindhoven Office
De Witbogt 15, 5652 AG Eindhoven, The Netherlands
TEL: +31 (0)40-8003800 / FAX: +31 (0)40-8003898

*We reserve the right to change the information in this catalogue without prior notice.